

**MODEL FSUGHP12**  
**HIGH PRESSURE GROOVED FLEXIBLE CONNECTOR**  
**± 12" MOVEMENT**

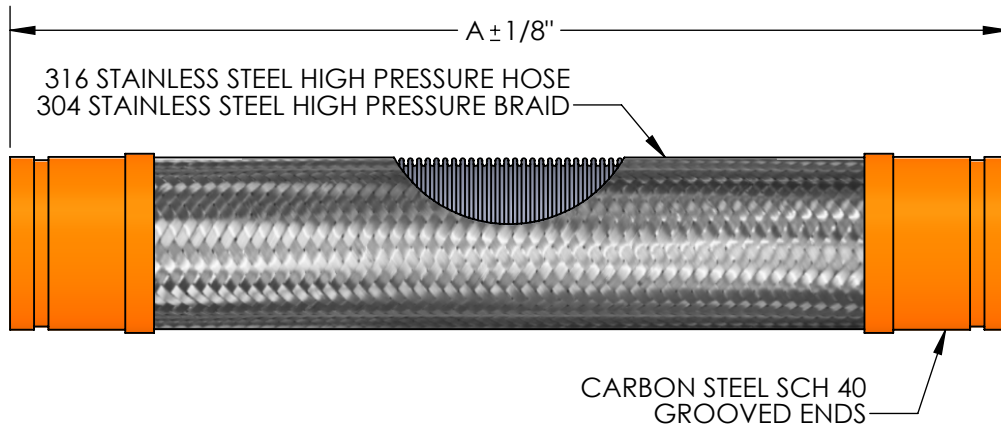

QTY	PART NUMBER	PIPE SIZE	A	BRAID	PRESSURE RATING (PSI)*	INTERMITTENT LATERAL OFFSET
	FSUGHP120400	4"	65-3/4"	DOUBLE	300	±12"
	FSUGHP120500	5"	60-1/4"	DOUBLE	300	±12"
	FSUGHP120600	6"	71-1/4"	DOUBLE	300	±12"

SUITABLE FOR USE IN DRY PIPE SYSTEMS  
 TEMPERATURES TO -40°F.

\*FOR SAFE WORKING PRESSURE ABOVE 70°F,  
 MULTIPLY THE PRESSURE SHOWN AT 70°F  
 TIMES THE CORRECTION FACTOR OF THE  
 REQUIRED TEMPERATURE.

TEMPERATURE (°F)	FACTOR
70	1.0
200	.91
300	.85
400	.78
500	.77
600	.76

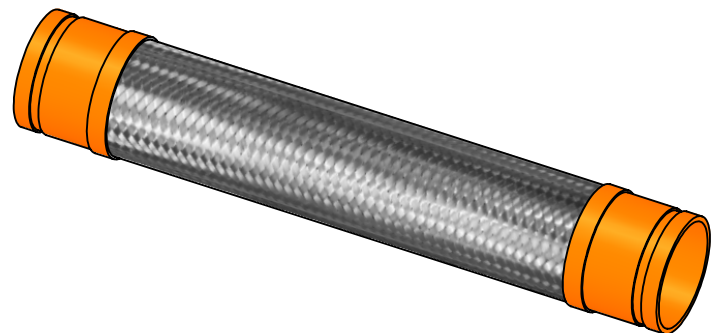

**NSF 372 - LEAD FREE**

The wetted surface of this product contacted by consumable water contains less than one quarter of one percent (0.25%) of lead by weight. Material complies with state codes and standards, where applicable, requiring reduced lead content.

CUSTOMER: \_\_\_\_\_

PROJECT: \_\_\_\_\_

ENGINEER: \_\_\_\_\_

REV.	DATE
2323 W. HUBBARD ST. CHICAGO, IL 60612 TEL: 312-738-3800 FAX: 312-738-0415 WWW.METRAFLEX.COM	
<b>MODEL FSUGHP12</b> UL LISTED GROOVED FLEXIBLE CONNECTOR FOR FIRE PROTECTION, ±12" MOVEMENT, HP H&B	
DRAWN BY: <b>DEVINR</b>	DATE: <b>01/03/2023</b>
APPROVED:	DATE:
SCALE: N/A	DRAWING NUMBER: FSUGHP12