

**MODEL MLPULHP
HIGH PRESSURE FLANGED FLEXIBLE CONNECTOR**

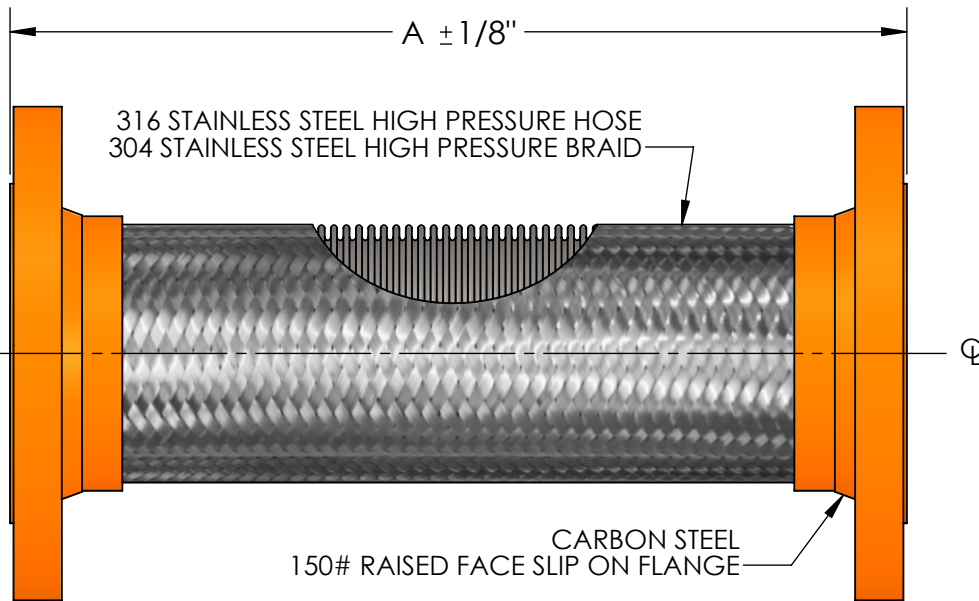

QTY	PART NUMBER	PIPE SIZE	A	BRAID	PRESSURE RATING (PSI)*	INTERMITTENT LATERAL OFFSET
	MLPULHP0400	4"	19-5/8"	DOUBLE	300	$\pm 3/4"$
	MLPULHP0500	5"	19-7/8"	DOUBLE	300	$\pm 3/4"$
	MLPULHP0600	6"	21-1/8"	DOUBLE	300	$\pm 3/4"$

SUITABLE FOR USE IN DRY PIPE SYSTEMS
TEMPERATURES TO -40°F .

*FOR SAFE WORKING PRESSURE ABOVE 70°F ,
MULTIPLY THE PRESSURE SHOWN AT 70°F
TIMES THE CORRECTION FACTOR OF THE
REQUIRED TEMPERATURE.

TEMPERATURE ($^{\circ}\text{F}$)	FACTOR
70	1.0
200	.91
300	.85
400	.78
500	.77
600	.76

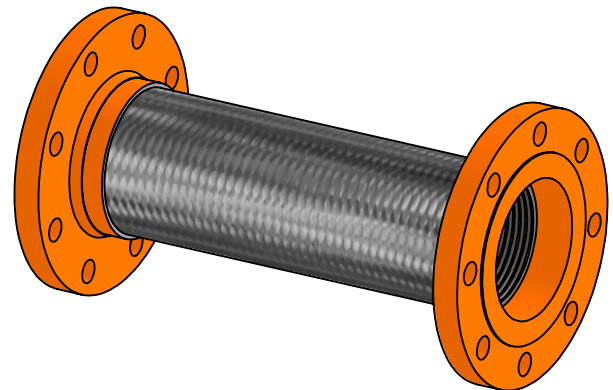

NSF 372 - LEAD FREE

The wetted surface of this product contacted by consumable water contains less than one quarter of one percent (0.25%) of lead by weight. Material complies with state codes and standards, where applicable, requiring reduced lead content.

CUSTOMER: _____

PROJECT: _____

ENGINEER: _____

REV.	DATE
2323 W. HUBBARD ST. CHICAGO, IL 60612 TEL: 312-738-3800 FAX: 312-738-0415 WWW.METRAFLEX.COM	
MODEL MLPULHP UL LISTED FLANGED FLEXIBLE CONNECTOR FOR FIRE PROTECTION, HP H&B	
DRAWN BY: DEVINR	DATE: 01/03/2023
APPROVED:	DATE:
SCALE: N/A	DRAWING NUMBER: MLPULHP